

# A Literature Survey on Non Invasive Blood Group Detection

Immaculate Stefi<sup>1</sup>, Dr Manasa Ravindra Walmiki<sup>2</sup>, Pallavi. K<sup>3</sup>

<sup>1</sup>Student & Dept. of Bio-Technology, Teresian College, Mysore

<sup>2</sup>Assistant Professor & Dept. of Bio-Technology, Teresian College, Mysore

<sup>3</sup>Student & Dept. of Bio-Technology, Teresian College, Mysore

**Abstract-** As we had observed that determination of blood group is very important and it is a basic test among all the test which are performed. During any emergency or if we are admitted to hospital, the very first thing the doctor will do is, determination of blood group. So, at a time of emergency even a minute delay may lead to death. Our proposed idea is a non-invasive method for identifying blood group. Light act as a source for optical signals which is allowed to pass through the finger and detector detects the varying voltage. Depending on the output voltage, the blood type is detected. Fortitude of blood type is vital before administering a blood transfusion in an emergency site. Presently these tests are performed manually by technicians in the laboratory, when the test is handled with large number of samples, it is monotonous to do and it may lead to human errors.

**Key Words:** Blood group, Antigen, Antibodies, LED, OPT 101 Detector

## 1. INTRODUCTION

As we all know blood is the important part and body fluid in human and different organism that transport necessary substances such as nutrients and oxygen to the cells and exit metabolic waste products away from these cells. Identification of blood group during transfusion of blood is very necessary for safe transfusion. Every individual has different type of blood group based on antigen present in their blood. There are four main type, Type A, Type B, Type AB and Type O. Individual Blood Groups are identified based on the Antigens are present on the surface of RBC. The major blood groups are ABO and Rh type [1].

Serious Injury may can cause high blood loss through bleeding. A healthy adult individual can lose almost 20% of blood volume before the first symptom and restlessness begins and around 40% of volume before shock sets in. It was Karl Landsteiner who discovered [2] the ABO blood group system in 1900 and rhesus factor later. For successful and safe transfusion, it is important to have information about the compatibility of donor and recipient blood group. An unequal or

mismatched transfusion would make blood clump, which would lead to serious significances and sudden death as well. Blood typing is a technique to state what type of blood you have. Blood typing is completed so you can safely donate your blood or receive a blood transfusion. It is also done to observe if you have a constituent called Rh factor on the surface of your red blood cell. The blood nature is based on whether certain proteins present on your RBC. These proteins are called antigens. There are four major blood type. They are: Type A, Type B, Type AB, Type O. Blood group typing refers to chemical reaction between specific antibodies and blood group antigens to view blood clumping. There is a wide range of various analytical test and tools for blood typing [3], including various test. The conventional test and further more test. Blood Groups are genetic and composed of RBC, WBC, Platelets, and Plasma. The fortitude of ABO Blood is depending up on the inherited properties of RBC by the presence or absence of Antigen A and Antigen B which are expressed on the surface of Red Blood Cells. In 1901, Austrian immunologist Karl Landsteiner first recognized the human ABO Blood group. The antigens present on the surface of RBCs is also known as agglutinogens and the antibodies that react against antigens are also called agglutinins. Antibodies are found in the plasma of blood [4]. Before that blood transfusion and transplantation were potentially fatal and risky. The Rh blood group system is one of thirty five known human blood group systems. Rh factor is a protein found on the surface of RBCs. If your blood has this protein than you are Rh positive and if this protein is not found than Rh negative. So now a days or earlier times the blood group is determined through manual process which is time consuming. And a minute delay during the transfusion or emergency situations may lead risk to patient life. Also, manual method or conventional method causes human errors during the procedure or there maybe misinterpretation in result during large samples. There is automated device used for blood group determination in large hospital, but they are large and expensive. The conventional method has multiple drawbacks, so a new device is implemented for detection of blood type.

### 1.1. ABO Blood Group System

There are 33 system present in blood among them ABO system is very important in transfusion and

transplantation. Blood group A contains different antibody with respect to blood group B and vice versa. Blood group O does not contain A/B antigen but both their antibodies in serum. There are two antigens mainly present on the surface of red blood cell and they are known as antigen A and antigen B. Antigens are sugar or proteins found on the surface of red blood cells. Antibodies are proteins which are mainly found in plasma (liquid component of blood).

- Blood group A: Have antigen A only
- Blood group B: Have antigen B only
- Blood group AB: Antigens A and B both are present
- Blood Group O: Antigens A and B are absent

If blood group A, then there will be antibodies to antigen B.

If blood group B, then there will be antibodies to antigen A.

If blood group AB, then you have antibodies to either A or B

## 2. VARIOUS TEST FOR BLOOD TYPING

In routine clinical examination, there is a wide range of conventional procedures and practices for blood group determination, where nearly all of them deal with blood clumping. There is wide spread range of blood keying procedures, which contrasts from each other in terms of sensitivity, reagents and equipment required, the time of operation and throughout analysis. There are several tests with their advantages and disadvantages.

### 2.1. Slide Test

This test is least sensitive method among other blood group determination. In this method, the donor or recipient blood is mixed with anti A, anti B and anti D separately on the slide. The blood clumping pattern can be visually observed from which ABO and Rh type blood is determined. The test complete within 10-15 min and is inexpensive. It is not reliable enough for completely safe transfusion.

### 2.2. Tube Test

This test is more sensitive and reliable in comparison to slide test. In this method both forward and reverse grouping is carried out. The forward grouping suggests the presence or absence of A and B - antigens in RBCs and reverse grouping indicates the presence or absence

of anti-A and Anti-B in serum. The blood is added into two test tube and one droplet of each antigen (ANTI-A and ANTI-B) is added separately in these samples. These tubes are kept for centrifugation for few minutes and then shaken to view =clumping of blood. The purpose of centrifugation is for proper mixing of blood with antigens.

Advantage: More sensitive than slide test, require low amount of reagent and some unexpected antigens can also be detected.

### 2.3. Microplate Technology

This method is fast with feasibility of automation for blood typing. In this technique, both antibodies in blood, plasma and antigens on RBCs can be determined. The microplate consists of large number of small tubes that contain a few microliters of reagent, which are treated against the blood samples. The centrifugation and incubation the clumping can be examined by an automatic readout device.

Advantage: fast response, low reagent volume and high throughput analysis.

### 2.4. Column/Gel Centrifugation

Column is composed of small micro tubes that comprises gel medium to trap agglutinates. Blood serum or cells are mixed with Anti-A, anti-B and Anti-D reagents in micro tubes under controlled incubation and centrifugation. The gel medium traps the agglutinates and non -agglutinated blood cells are allowed to pass through the column.

Advantages: sensitive, straightforward and relatively easy to operate for less trained personnel.

**Table 1:** Various Test for blood typing

Test	Principle	Intended for	Analysis -time	Applicability	Remark
Slide	Agglutination	simple blood group detection	10 min	Hospitals, clinical laboratories	Least sensitive, but low cost; require small volume, rapid result
Tube	Agglutination	Blood group detection and antibody screening	10-30 min	Hospitals, clinical laboratories	Intermediate sensitivity and time consuming
Micro-plate	Agglutination	Blood group detection and antibody screening	10-30 min	Hospitals, clinical laboratories	Fast and highly sensitive
Gel	Agglutination	Blood group detection	10-45 min	Hospitals, clinical laboratories	Highly sensitive but time consuming

**OPT101 Detector:** The OPT101 is a monolithic photodiode with on-chip trans impedance amplifier. It is the combination of photodiode and impedance amplifier on single chip. It is used to convert the light into voltage. The photodiode collects significant amount of light, and thus allows for high sensitivity measurements.

The integrated combination of photodiode and trans impedance amplifier on a single chip removes the risk commonly encountered in discrete designs such as leakage current errors, noise, pick-ups and gain peaking as a result of stray capacitance. Resultant voltage increases linearly with light intensity. The amplifier is designed for single or dual power supply operation.

The 0.09x0.09-inch photodiode operates in the photoconductive mode for excellent linearity and low dark current. The OPT101 operates from 2.7 V to 36V supplies and quiescent current is only 120 microamperes.

**Arduino board:** Arduino UNO is used for interfacing. The voltage level sensed by the OPT101 detector is processed with the help of arduino. And the processed or resultant output is displayed on display. As different individual lies in the different range of voltage, the intermediate range can be observed for different kind of blood group, after taking a lot of observation and by performing this test with different individuals.

It is a microcontroller board based on the ATmega328 microcontroller. It has 14 input/output pins which are used for interfacing. The Arduino board is fortified with collections of digital and analog input/output pins that may be interfaced to various expansion boards and other circuits.

It also consists of 16 MHz ceramic resonator, an ICSP header, a USB connection, 6 analog i/p, a power jack and reset button. With the help of USB connector, the processed o/p is easily displayed on PC by connecting PC and Arduino board.

**PC Display:** The obtained output is viewed in the PC. Through OPT 101 detector the light is converted into voltage levels is measured and the detected voltage levels is measured and readout through the PC. The Light from LED is passes through finger.

The light will deflect/scatter from the specimen and is detected by OPT 101 detectors. The OPT 101 detector is a light to voltage device. It will convert the light into voltage levels. There are Optical variations in blood and voltage level present in blood. So on the basis of voltage variation, blood type is detected.

### 3. PROPOSED SYSTEM

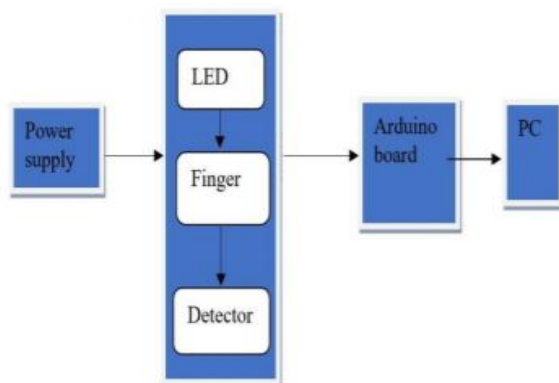

Fig 1: Blockdiagram of proposed system

#### 3.1. Components

**LED:** A light emitting diode is a p-n junction diode that emits light when energized. When current is applied to both of its lead, energy is released in the form of photon. So, the LED light is passed through the finger and the light gets reflect/deflect or pass. The scattered light is detected by the detector OPT101.

The first part consists of a sensor. In that sensor, there are two IR and red LED whereas light detector is on other side. A finger is placed between the two LEDs and the light detector for sensing blood voltage in the finger. For example, same kind of probe is used which is used in pulse oximeter.

### 3.2. Electrical properties of blood

Apart from electrical properties, blood also possess chemical and mechanical properties. The research found and determined the pathways of current flow through the body. The electrical properties of blood play a vital role in the analysis of biomedical application such as diagnosis and therapeutic treatment of various physiological conditions with weak/low electric currents, radio frequency hyperthermia and ecg. The constituents of electrical properties of blood are alternating current and spectroscopy. These properties are viewed over the range of less than 100 Hz.

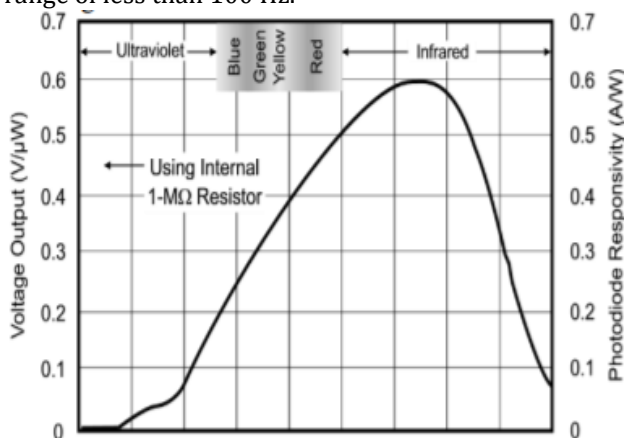

Fig 2: Spectral Responsivity

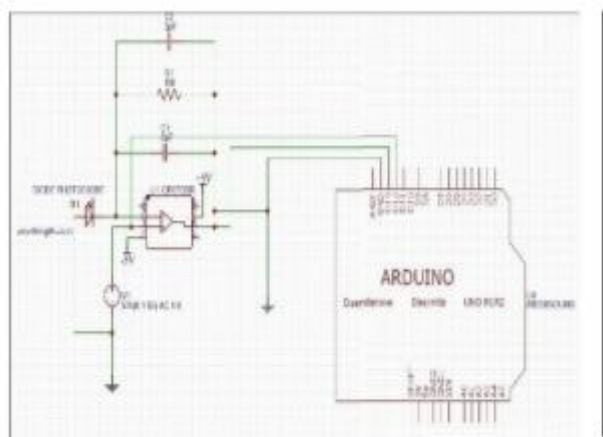

Fig 3: Schematic Diagram of proposed system

### 4. RESULT AND DISCUSSION

By collecting the data of various subjects, we found a certain range of voltages for different blood group. As the blood possess optical property, there are different range of voltage for different blood group and it varies from person to person.

Table 2. Results

Blood group	Voltage
A	0.56-0.58
B	0.59-0.60
AB	0.61-0.62
O	0.53-0.55

As shown in above table there are four different ranges of voltage available for four different kinds of blood group. The person with respective blood group has been found with the voltage level of that respective kind of blood group. Like person with blood group A has voltage level from 0.56 to 0.58, with any of the number of these range.

### 5. CONCLUSION

We had referred to many reputed journal papers and understood the various methods for determining blood group. There were advantages and limitations in the following papers, we had gone through them and came up with a new solution with the help of those papers. The problem of human errors, time consumption, very large size machine are solved by this proposed device. The proposed device is compact, low cost and easily available. The blood group is detected in very less amount of time compared to conventional method. There is no need of puncturing the skin, it is non-invasive way for determining blood type. And we had mentioned the result by collecting the data of various people and by observing that we had analysed the range of different blood group.

### REFERENCES

- [1] Laura. (2005), 'Blood groups and red cell antigens', National Center for Biotechnology Information
- [2] Mujahid, Adnan, and Franz L. Dickert. (2015), Blood group typing: from classical strategies to the application of synthetic antibodies generated by molecular imprinting Sensors 16, no. 1, pp: 51.
- [3] Selvakumari, T.M. (2011), Blood Group Detection Using Fiber optics, Armenian Journal of Physics 4, no. 3, pp: 165- 168.
- [4] Gaurav.S.Mehare, Chetan.G.Pinjarkar, Anup.V.Tembhe, Prof. Nitin.S.(2019), A noninvasive way to determine blood type based on image processing, International Research Journal Of Engineering and Technology, Vol:5.
- [5] Ferraz, A., V. Carvalho, and F. Soares. (2010), Development of a human blood type detection

automatic system, *Procedia Engineering* 5, pp: 496-499.

- [6] Ashiba, Hiroki, Makoto Fujimaki, Koichi Awazu, Mengying Fu, Yoshimichi Ohki, Torahiko Tanaka, and Makoto Makishima. (2015), Hemagglutination detection for blood typing based on waveguide-mode sensors. *Sensing and BioSensing Research* 3,pp: 59-64.
- [7] A. Narkis Banu, V. Kalpana. (2018), An Automatic System To Detect Human Blood Group Of Many Individuals In a Parallel Manner Using Image, *International Journal of pure and applied mathematics*,Vol:118
- [8] Kanade, Vijay A. (2015), Bio-Optics: Blood Type Determination based on Image Processing Techniques by utilizing an Optical Sensor Device, *International Journal of Science and Research* 5, no. 7 ,pp: 214-217.
- [9] Nagar, Nishtha, Aesha Shah, Aditya Singh and Shreya Akotiya.(2015) Blood Group Detection and Mobile Monitoring System.
- [10] Katti, Pooja Naragund, Vaibhavi Sara desai, Pyati Vidhyashree, Kaushik M, Anilkumar V Nandi, Vaishali B Mungurwadi .(2015)
- [11] Blood MEMS based sensor for blood group investigation, *Cosmol Conference*,Vol:01.
- [12] Sahastrabuddhe, Akshaya P., and Sayyad D. Ajj. (2016), Blood group Detection and RBC, WBC Counting: An Image Processing Approach, *International Journal of Engineering And Computer Science* 5, no. 10.
- [13] Gayathri T, Rekha M, NaizathulAkmah, K. Nithya Kalyani.(2018), Non-Invasive blood group detection using Light Emitting diode, *International Journal of Pure and applied Mathematics*, Vol:119.
- [14] Daniels, G. (2002) Human blood groups, pp : 7-98.
- [15] Mehedi Hasan Talukdar, Md. Mahfuz Reza, Mehbuba Begum, Md. Rabiul Islam, Md. Mahmudul Hasan.(2015),Improvement of accuracy of human blood groups determination using image processing techniques, *International Journal of Advance research in Computer and Communication Engineering*, Vol:4